

An Electronic Analyzer for Indoor Climate*

P. Marx

Technische Fachhochschule Berlin, Fachbereich 12 — Elektrotechnik, Luxemburger Str. 10, 1000 Berlin 65, West Germany

and

G. Schlüter

Bundesgesundheitsamt, Institut für Wasser-, Boden- und Lufthygiene, Corrensplatz 1, 1000 Berlin 33, West Germany

A new measuring device for rapid analytical determination of thermic indoor climate components has been developed. The device consists of:

- (1) a measuring bulb with two pyroelectric conductor sensors for air temperature measurement (dry and humid) as well as two measuring bulbs for the recording of cooling caused by convection and heat radiation;
- (2) the electronic part with power supply, amplifiers, and recording instrument of precision class O.5.

Relative humidity is determined from the psychrometric difference. The mean temperature of the surrounding surface results from simultaneous measurement of cooling by convection (gold-plated measuring bulb) as well as cooling by convection plus radiation (black measuring bulb). Air movement results from convective cooling of the gold-plated bulb and air temperature. The physical relationships are based on a nomogram which is used also for the evaluation and recording of the measurements. The device has a power supply, battery operation is optional. For programme-controlled measurements, a computer interface has been provided.

Introduction

For measuring the indoor climate, devices are often used which separately detect, indicate, or record the single components of indoor climate such as air temperature, air velocity, air humidity, and mean radiant temperature. These devices are generally expensive. Cumulative measuring devices are less expensive but associated with other undesirable features. Instead of using different specific measuring systems for the determination of indoor climate, it is appropriate to determine the different indoor climate components separately, but with a specially designed universal system. A recently developed indoor climate measuring device of this kind, which is compact and easy to handle, and adequately accurate is discussed in the following section.

Mechanical and pyrometric design of the indoor climate analyzer

The indoor climate analyzer is segmented into the sensor and the indicator parts. The indicator parts contain the power supply and the electronic control switchgear

and are connected to the sensor parts by a screened multi-strand cable (see Fig. 1).

The climate data recorded by the sensor part can be read from the indicator scale in accordance with the position of the selector switch. Air sucked through the sensor tubes using a fan contains 2 NTC. The response time is reduced by the action of the fan. One thermometer measures the temperature of dry air. A second thermometer is provided with a moistened cloth similar to Aßmann's aspiration psychrometers. This thermometer measures the temperature at which the indoor air is saturated with water without increasing its heat content. The relative humidity is calculated from the psychrometric difference of the readings of the two thermometers Fig. 2.

The sensor part is also equipped with 2 bulb-shaped primary elements for determining the cooling intensity of the environment. Each of the bulbs consist of a resistance wire winding, coated with a thin plastic film, and kept at 36.5°C using a NTC-thermometer. The necessary electric heating power serves as a measure for the rate of the cooling capacity of the environment. By its small capacity of heat storage and high capacity of thermal conductivity, the mechanical construction of the bulbs guarantees the immediate adjustment of heating power supplied to the changes of the external thermic stimulus. Thus, while maintaining a constant

*Received April 1978; received in final revised form 24 October 1979

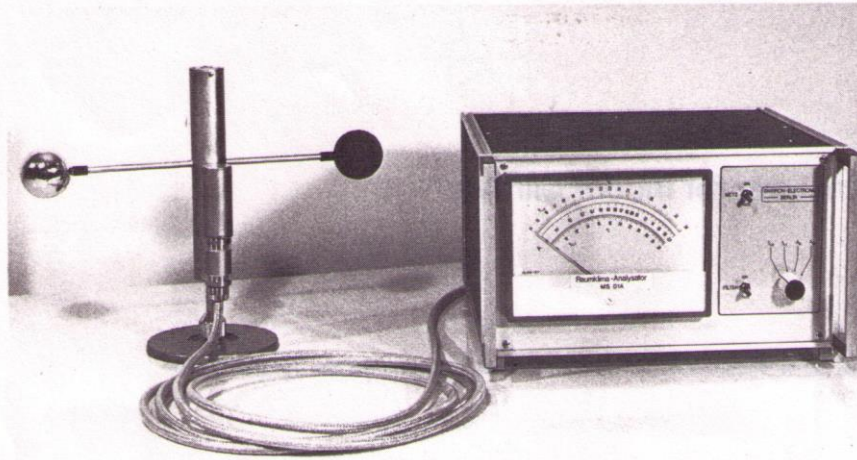

Fig. 1. Indoor climate analyzer (sensor and indicator parts).

bulb temperature, an inertial-free indication of the cooling capacity is rendered possible. In order to eliminate mutual interference and to prevent a loss of heat by conductivity, both bulbs are fitted at an adequate distance from each other.

The surface on one of the bulbs is gold-plated, i.e. its heat radiation is achieved almost exclusively by convection. It is well known that air movement may be determined from the convective cooling of a body and the temperature of the cooling air. Measuring air movement is thus performed by the indoor climate analyzer according to this principle. By joining the values for air temperature t_{L-r} and convective cooling A_K — measured with the gold-plated bulb — the air movement may be read from a nomograph based on air velocity. The other bulb is blackened at its surface, i.e. it loses its heat by radiation in addition to convection to the room surfaces. The colder these surfaces, the greater is cooling by radiation. Due to the pronounced difference of the radiation numbers of both bulbs, the difference of their cooling values $A_G - A_K$ is a measure of the temperature of the surrounding surfaces if a mean heat radiating value of emission for ceilings, walls, and floors is applied. The black bulb shows the total cooling A_G , while the radiation-protected bulb shows mainly the cooling by convection A_K . From numerous simultaneous measurements of temperatures of surrounding surfaces t_V performed with thermocouples fixed to walls, on the one hand, and cooling value differences $A_G - A_K$ with the indoor climate analyzer on the other, the following analytical equation was found:

$$A_G - A_K = \left[\frac{(t + 273)^4 - (t_v + 273)^4}{94.34 \cdot 10^7} \right]^{1.02} \cdot 0.279 \text{ [Watt]}$$

This equation permits the establishment of a comparative scale between $A_G - A_K$ and t_V in the evaluation nomograph where t is surface temperature of the black bulb = 36.5°C.

The empirically single values had an average scatter

of surface temperature of $\pm 0.5^\circ\text{C}$. The cooling values A_G and A_K are dependant on the equipment and must not be related to the deheating of the human body. They serve only as coefficients for the determination of air movement and temperature of the surrounding surfaces.

Electronic design of the indoor climate analyzer

The wiring diagram of the indoor climate analyzer is shown in Fig. 3. A voltage regulator (Dual) provides for an operating voltage with a stability of $\pm 0.01\%$. Air temperatures are measured by the pyroelectric conductors 1 and 2 in connection with the measuring amplifiers V_1 and V_2 . The electronic regulation of temperature of the black bulb and the radiation-protected measuring bulbs is performed through the pyroelectric conductors 3 and 4, and the automatic control and output amplifiers V_3 , VL_3 , V_4 , and VL_4 .

The operating switch permits a selection of the desired variable to be measured which is indicated by the moving-coil instrument (0.5% class). The electronic part is of a printed circuit design. Six integrated circuits are used. For the discrete transistors and diodes only silicon semiconductors were utilized.

Measuring ranges of the indoor climate analyzer

The indoor climate analyzer for which a patent application has been filed works on power supplied from the public grid. The indicating ranges are comprised one of $14^\circ - 34^\circ\text{C}$ in a $2/10^\circ$ graduation for air temperature, and one of $8^\circ - 30^\circ\text{C}$ in $2/10^\circ$ for the wet bulb temperature. The nomograph permits an exact determination of the relative humidity from 10 to 100% at an atmospheric pressure of approximately 775 mm Hg. The average error of indication may increase to $\pm 1\%$ of relative humidity between 700 and 770 mm Hg. For higher differences of air pressure, (e.g. at measurements at high altitudes) the usual correction factors have to be applied. The extension of the straight line connecting the t_{L-r} and t_{L-f} data yielding the relative humidity at its

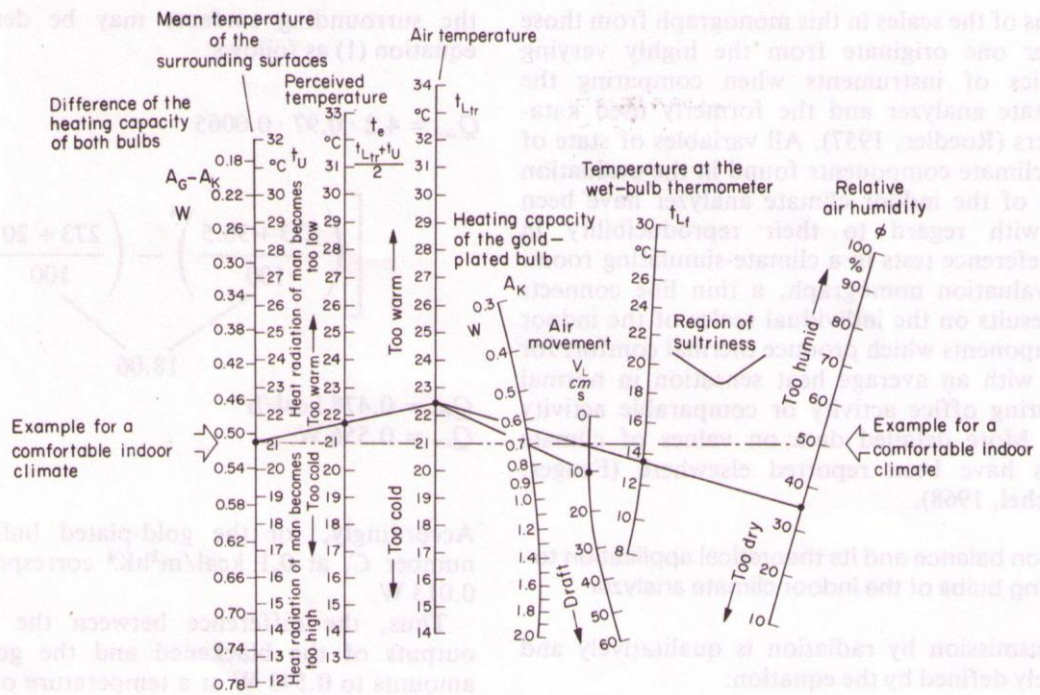

Fig. 2. Nomograph for determination of indoor climate from the individual components measured with the indoor climate analyzer. Example: air temperatures are measured (indicated in the figure by t_L) $t_{tr} = 22.5^\circ\text{C}$ and $t_f = 13.5^\circ\text{C}$. A straight-line connection of these values will yield $\phi: 35\%$. If, for example, $A_K = 0.7\text{ W}$, connection of this value with t_{tr} will yield an air velocity of 10 cm/s . If at the same time a total cooling is measured of e.g. $A_G = 1.21\text{ W}$, $A_G - A_K = 0.51\text{ W}$ is resulting and thus $t_U \approx 21.0^\circ\text{C}$. Connection of t_U with t_{tr} yields $t_e \approx 21.8^\circ\text{C}$.

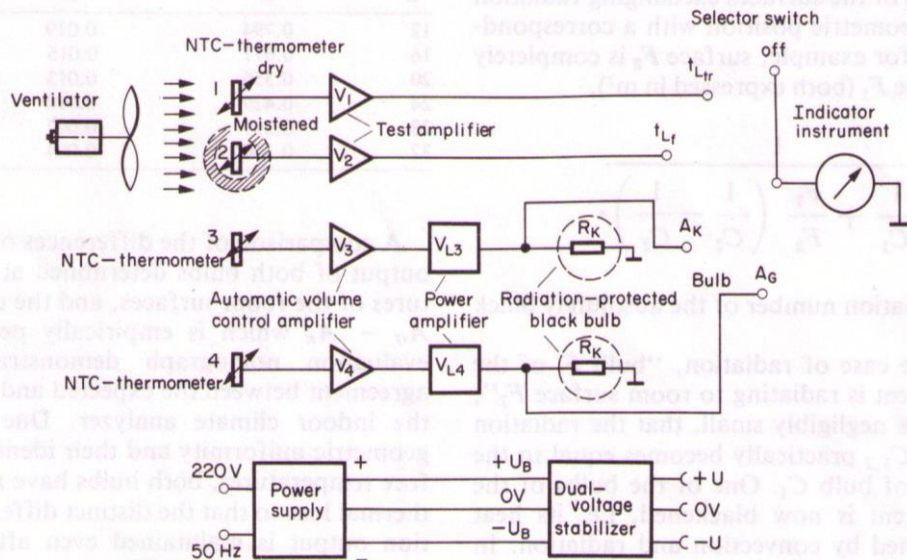

Fig. 3. Block diagram of the indoor climate analyzer.

point of intersection with the ϕ -scale should not pass through the range of sultriness according to Lancaster-Castens (Schlüter, 1963) as registered in the evaluation nomograph. The ranges of the cooling values are selected in such a way that the temperatures of the surrounding surfaces of $12 - 32^\circ\text{C}$ may be registered. The "sensation temperature" (Schlüter, 1963) calculated as the arithmetic mean of the temperatures of

air and surrounding surfaces is plotted as a scale in the evaluation nomograph. A connection of the measured values of t_{L-tr} and t_U yields t_e . In the evaluation nomograph (Fig. 2) air velocities between 0 cm/s stagnant air and 60 cm/s may be detected as a result of convective cooling and air temperature. Moreover, the ranges of the single components can be read from the evaluation nomograph.

Deviations of the scales in this monograph from those of a former one originate from the highly varying characteristics of instruments when comparing the indoor climate analyzer and the formerly used kathermometers (Roedler, 1957). All variables of state of the indoor climate components found in the evaluation nomograph of the indoor climate analyzer have been examined with regard to their reproducibility in numerous reference tests in a climate-simulating room.

In the evaluation nomograph, a thin line connects those test results on the individual scales of the indoor climate components which produce thermal comfort for individuals with an average heat sensation in normal clothing during office activity or comparable activity conditions. More detailed data on values of climate components have been reported elsewhere (Fanger, 1970; Rietschel, 1968).

Heat radiation balance and its theoretical application to the measuring bulbs of the indoor climate analyzer

Heat transmission by radiation is qualitatively and quantitatively defined by the equation:

$$Q_{str} = c_{1,2} \cdot \varphi_{1,2} \cdot F_1 \left[\left(\frac{T_1}{100} \right)^4 - \left(\frac{T_2}{100} \right)^4 \right] \quad (1)$$

(extension of Stefan-Boltzmann's Law).

The radiation exchange number $C_{1,2}$ (kcal/m²hK⁴) is given variable values expressing the individual radiation numbers C_1 and C_2 of the surfaces exchanging radiation according to the geometric position with a corresponding value. If thus, for example, surface F_2 is completely surrounding surface F_1 (both expressed in m²),

$$C_{1,2} = \frac{1}{\frac{1}{C_1} + \frac{F_1}{F_2} \left(\frac{1}{C_2} - \frac{1}{C_2} \right)}$$

where C_s is the radiation number of the absolutely black surface.

If applied to the case of radiation, "bulb F_1 of the measuring equipment is radiating to room surface F_2 ", this means, as F_1 is negligibly small, that the radiation exchange number $C_{1,2}$ practically becomes equal to the radiation number of bulb C_1 . One of the bulbs of the measuring equipment is now blackened, i.e. its heat transfer is performed by convection and radiation. In this case 4.2 kcal/m²hK⁴ is the radiation value for the mat lacquer to be found in the respective special literature (Gröber, 1963; Kollmar, 1957) which is the dihedral angle relationship of the surfaces in the radiation exchange. For a bulb in the room, $\varphi = 1$; however, in the case of the indoor climate analyzer, the bulbs are slightly covered by the main tube; thus in this case a value of 0.97 has to be used for φ . The surface of the bulbs of the measuring equipment F_1 is 0.0065 m², and its temperature 36.5°C. Assuming a mean temperature of the surrounding surfaces t_v for a room of any kind at 20°C, the heat radiation output of the bulb radiated to

the surrounding surfaces may be determined from equation (1) as follows:

$$Q_{str} = 4.2 \cdot 0.97 \cdot 0.0065 \cdot$$

$$\left[\left(\frac{273 + 36.5}{100} \right)^4 - \left(\frac{273 + 20}{100} \right)^4 \right]$$

18.06

$$Q_{str} = 0.478 \text{ kcal/h}$$

$$Q_{str} = 0.556 \text{ W}$$

Accordingly, for the gold-plated bulb, a radiation number C_1 at 0.1 kcal/m²hK⁴ corresponds to $Q_{str} = 0.013 \text{ W}$.

Thus, the difference between the heat radiation outputs of the blackened and the gold-plated bulb amounts to 0.543 W at a temperature of the room surfaces t_v of 20°C. The results of the same calculation at other temperatures of the room surfaces can be seen from Table 1.

Table 1. Heat radiation output of the measuring bulbs at different temperatures of the room surfaces t_v

t_v °C	Heat radiation output of the measuring bulbs		Difference of heat radiation output W
	Black bulb W	Gold-plated bulb W	
12	0.794	0.019	0.775
16	0.677	0.016	0.661
20	0.556	0.013	0.543
24	0.429	0.010	0.419
28	0.297	0.007	0.290
32	0.160	0.004	0.156

A comparison of the differences of the heat radiation output of both bulbs determined at different temperatures of the room surfaces, and the comparing scale $t_v/A_G - A_K$ which is empirically performed using the evaluation nomograph demonstrates a reasonable agreement between the expected and obtained results of the indoor climate analyzer. Due to their absolute geometric uniformity and their identical controlled surface temperatures, both bulbs have an equal convective thermal loss so that the distinct difference of heat radiation output is maintained even after addition of the convective proportion. Thus, the mean surface temperature of the room surfaces may be determined with a precision of $\pm 0.5^\circ\text{C}$ in the case of equal convection of both bulbs.

If a measurement of air humidity is performed at an atmospheric pressure deviating from 755 Torr, the nomograph (Fig. 4) is used for correction. An example shown here explains the correction procedure, the result of which provides for a precision within 0.5% of the relative humidity in cases of all possible combinations between atmospheric pressure, air temperature, and humidity.

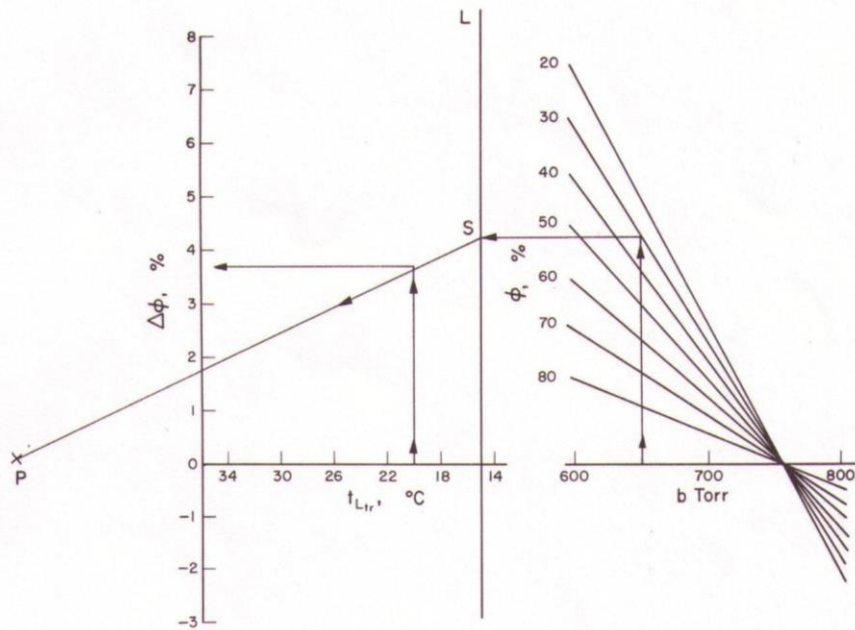

Fig. 4. Correction nomograph for relative humidity determined at 755 Torr at deviating air pressure b and different air temperatures t_{Lir} . Example. $b = 650$ mm Hg; $\phi = 30\%$; $t_{Lir} = 20^\circ\text{C}$; from air pressure b vertically to the line; from there horizontally to the directrix L ; then S will result. Join S with P . From t_{Lir} vertically to the connection $S - P$, from there horizontally to the scale for $\Delta\phi$.

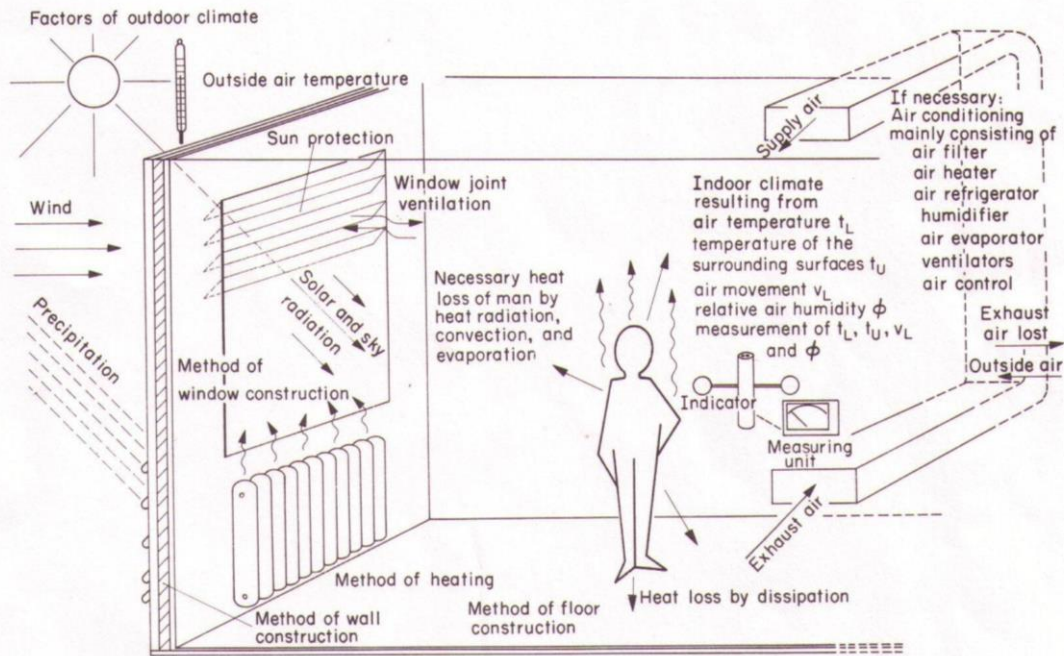

Fig. 5. Man in the thermic indoor climate.

References

Fanger, P.O. (1970) *Thermal Comfort*. Danish Technical Press, Copenhagen.
 Gröber, H., Erk, S. and Grigull, U. (1963) *Grundgesetze der Wärmeübertragung*. Springer, Berlin-Göttingen-Heidelberg.
 Kollmar, A. and Liese, W. (1957) *Die Strahlungsheizung*. Oldenbourg, München.

Rietschel/Raiß (1968) *Lehrbuch der Heizungs- und Lüftungstechnik*. Springer, Berlin-Göttingen-New York, 15th Ed., Vol. 1.
 Roedler, F. (1957) *Hygienische Grundlagen der Klimatechnik*. *Ges. Ing.* 78, 1.
 Schlüter, G. (1963) Schlierenoptisches Sichtbarmachen feinsten Luftströmungen in der wärmephysiologischen und raumklimatischen Forschung. *Ges. Ing.* 84, 48.